

## RDG160T

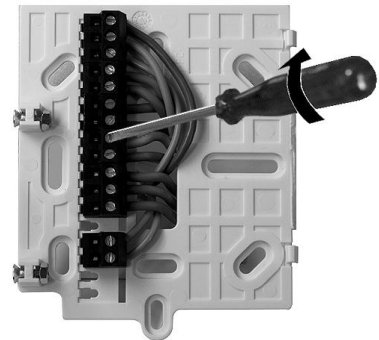

Max. 1 x 2.5 mm<sup>2</sup> (1 x 14 gauge)  
Max. 2 x 1.5 mm<sup>2</sup> (2 x 16 gauge)

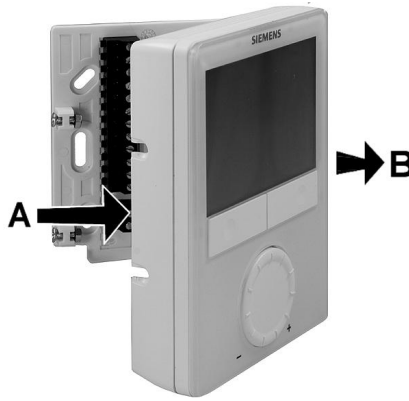
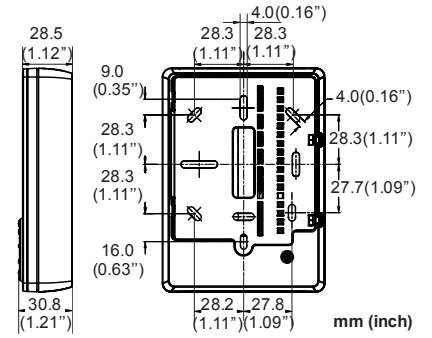
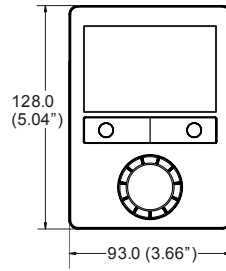
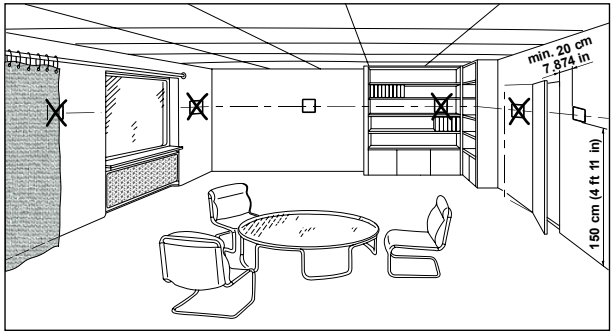

Max. 80 m (262 feet)

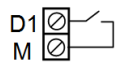
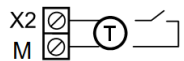
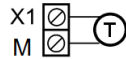

P3181

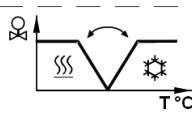

3181Z111

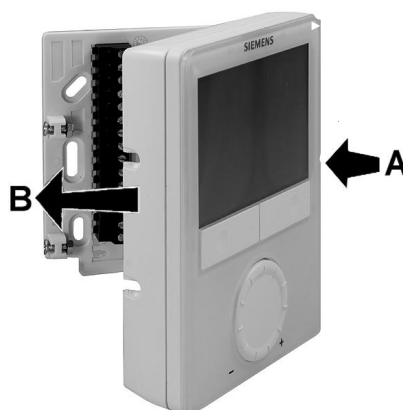
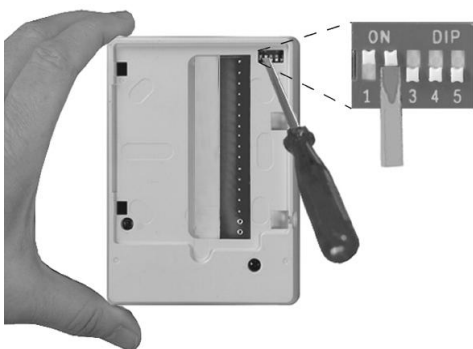
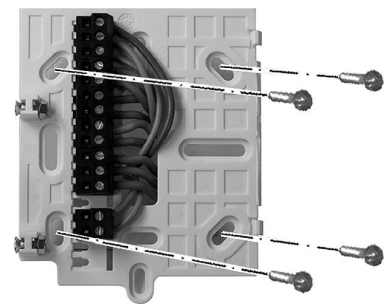

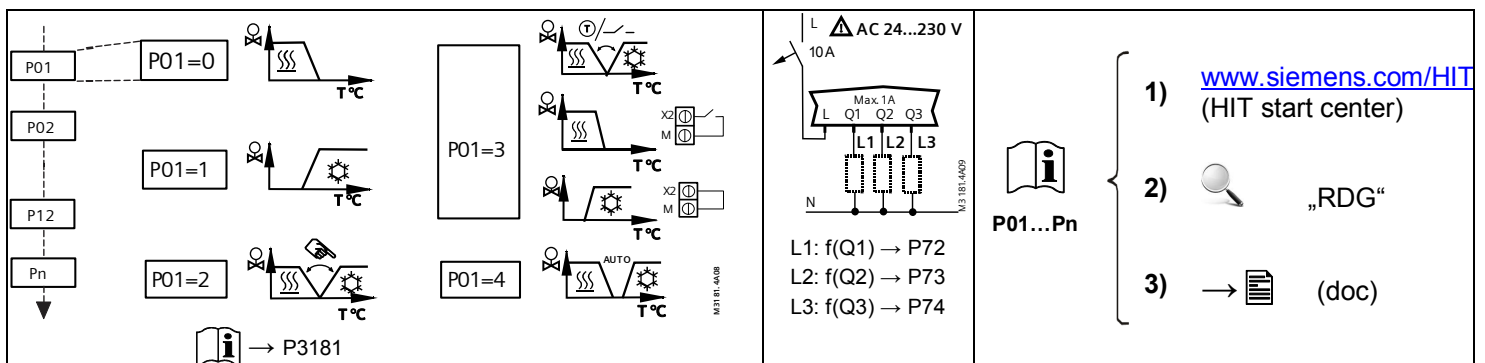
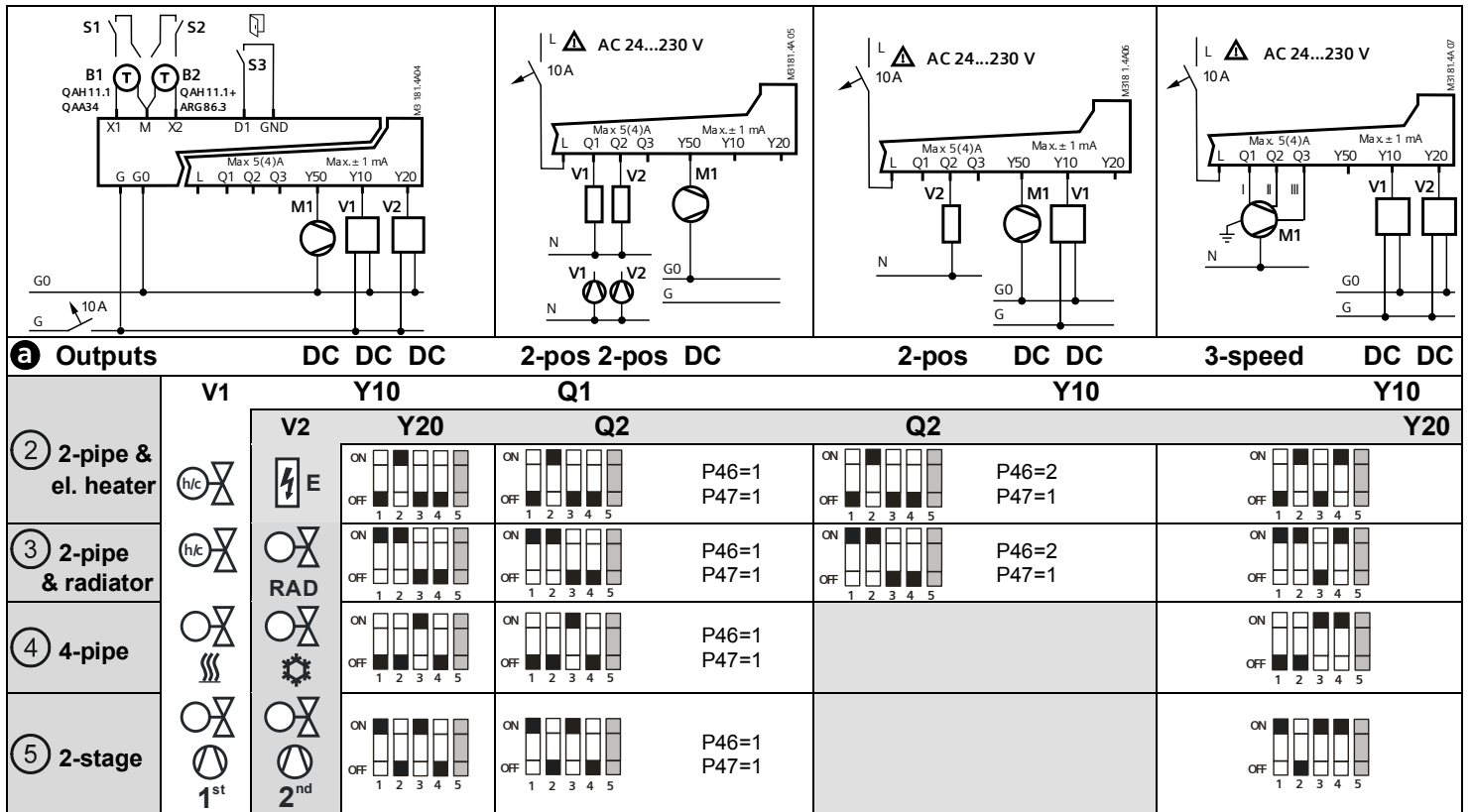
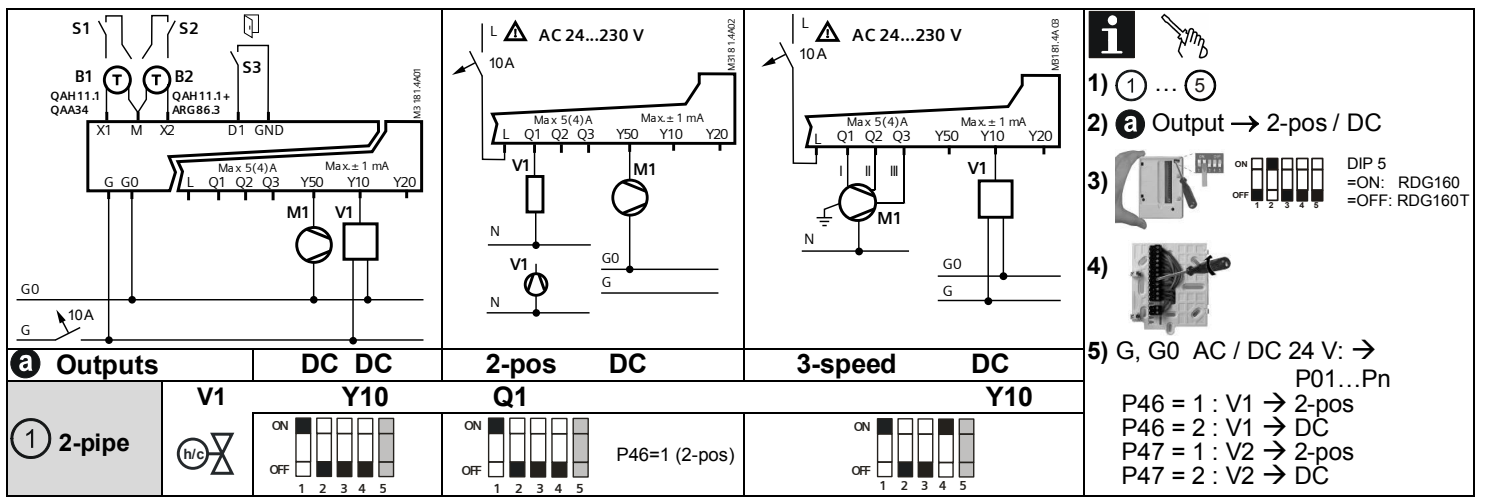

	en	de	fr	it	es	cs	tr
<b>1</b>	2-pipe fan coil	2-Rohr Ventilator-konvektor	Ventiloconvecteur 2 tubes	Fan coil 2 tubi	Fancoil a dos tubos	2-trubkový fan-coil	2 borulu fan coil
<b>2</b>	2-pipe & el. heater	2-Rohranwendung & Elektroheizung	Application 2 tubes & batterie électrique	Fan coil 2 tubi con batteria elettrica	2 tubos & batería eléctrica	2-trubkový fan-coil & el. ohřev	2 borulu & elk. Isıtıcı
<b>3</b>	2-pipe & radiator	2-Rohranwendung & Radiator	Application 2 tubes & radiateur	Fan coil 2 tubi e radiatore	2 tubos & radiador	2-trubkový fan-coil & radiátor	2 borulu & radyatör
<b>4</b>	4-pipe fan coil	4-Rohr Ventilator-konvektor	Ventiloconvecteur 4 tubes	Fan coil 4 tubi	Fancoil a 4 tubos	4-trubkový fan-coil	4 borulu fan coil
<b>5</b>	2-stage	2-Stufen-Anwendung	Application à 2 étages	2 stadi	2 etapas	2-stupňový	2 kademe



Офіційний партнер

# Teplota



Teplota.UA

**CLICK**

